



PRIMO[®] XXL

Comfort Seat with
Pneumatic Suspension



CAPITALseating

www.capitalseating.co.uk

tel: +44 (0)116 216 9910 | email: grammer@capitalseating.co.uk



GRAMMER

TECHNICAL DATA

PRIMO® XXL

Despite this seat's low height, its large suspension travel and low-frequency technology actively protect the user. It's also very easy to set the pneumatic suspension and extra-high backrest with mechanical lumbar support. The push-button weight adjustment feature is especially advantageous in vehicles used by changing drivers.



Pneumatic suspension



Low-Frequency Suspension



Mechanical Lumbar Support



Manual Weight Adjustment

Features ● Standard ○ Optional

	PRIMO® XXL
Article no. fabric Compressor 12V	1293476
Shock absorber nonadjustable	●
Suspension	
Pneumatic suspension with compressor	●
Low-frequency suspension	●
Suspension stroke 110 mm	●
① Weight adjustment 45 - 170 kg, pneumatic	●
② Fore/aft adjustment 210 mm	●
③ Lumbar support mechanical	●

	PRIMO® XXL
④ Adjustable backrest angle	●
⑤ Restraint system	●
Seat cushion width	450 mm
Operator presence switch (OPS)	●
OPTIONAL FEATURES	
⑥ Document box	○
⑦ Armrests height-adjustable	○
Fore/aft isolator*	○
⑧ Seat heating	○

* Fore/aft isolator not for earth-moving machinery

Measurements (installation dimensions)

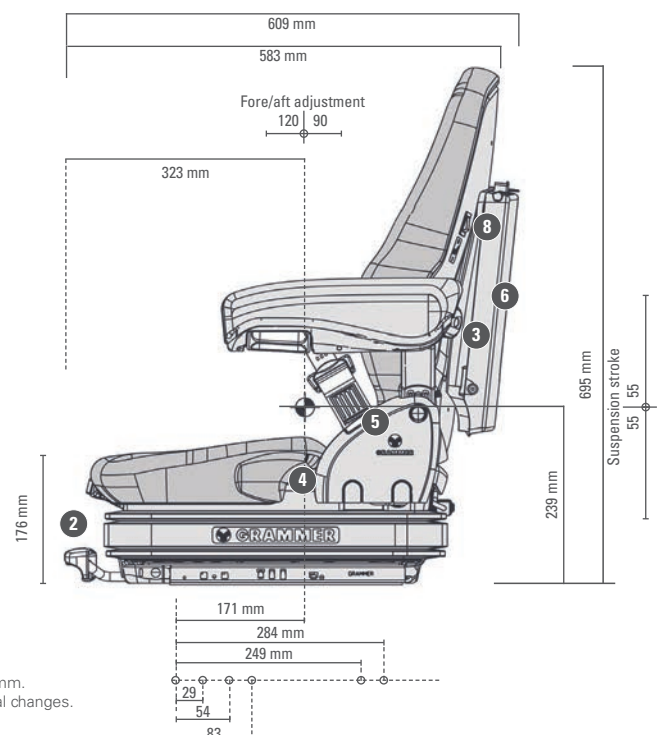
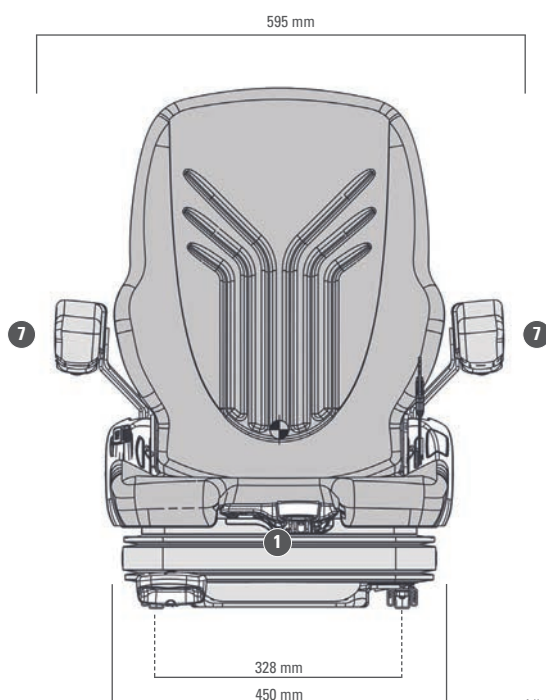

All dimensions in mm.
Subject to technical changes.