

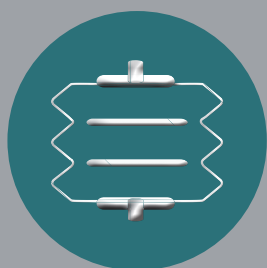

# INNOVATIVE SEATING SYSTEMS

Sitting Comfort and  
Modularity for Regional Trains

GRAMMER Rail & Bus is the leading provider of seating systems for rail and buses. As a full-line supplier of passenger and driver seats for public transport services, we offer a full range of seats for high-distance, intercity, regional and city traffic. We supply individual solutions addressing all customer requirements and, with our products, set standards in comfort, ergonomics, design, modularity, safety and economic efficiency. Backed by ongoing research and a steady flow of new innovations, we provide seating comfort that feels good – both on the rail track and on the road.



Second suspension



EN 45545



Pocket springs



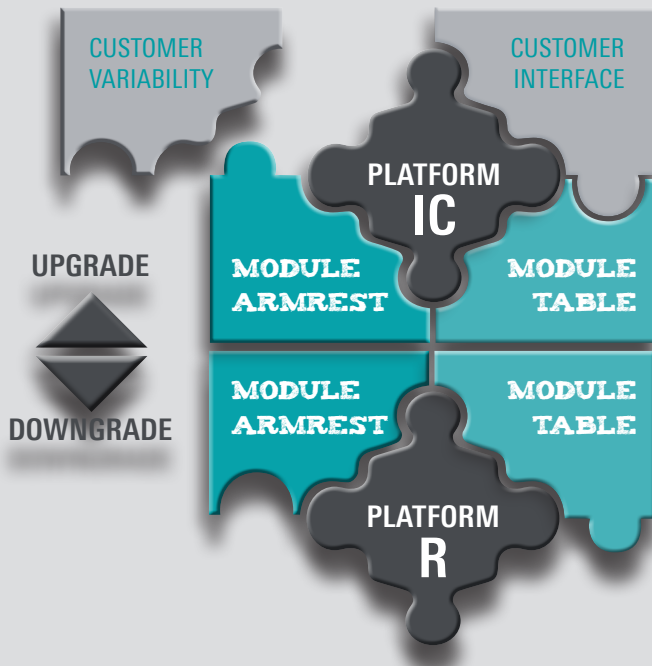

## MODULAR STRATEGY

Offering infinite possibilities for combination – creating limitless comfort



### **Second suspension**

*Second suspension optimizes the individual seating response. Individually adjustable hardness levels and different comfort zones offer optimum seating comfort.*



### **Pocket springs**

*Pocket-spring upholstery adjusts much more effectively to the contour of the human body. It is more durable than conventional upholstery and offers better ventilation as the air can circulate through each individual spring, thus allowing moisture to dissipate efficiently.*



*The advantages of both systems can be combined to achieve maximum seat comfort.*



Discover the countless possibilities offered by our modular designs with their numerous comfort upgrades and downgrades.

Using as a basis our standardized seat structures and the customized modularity of the interfaces, you can add or replace carry-over parts such as armrests, footrests, tables, bases or pivots as you like.

As well as this, we offer you a large number ergo-mechanic features. In addition to the GRAMMER ergomechanics® inside  in all back adjustments, you can select from the following seat comfort upgrades:

- > Second suspension
- > Pocket springs

This gives rise to countless different combinations for your individually designed seat, removing all limits to comfort

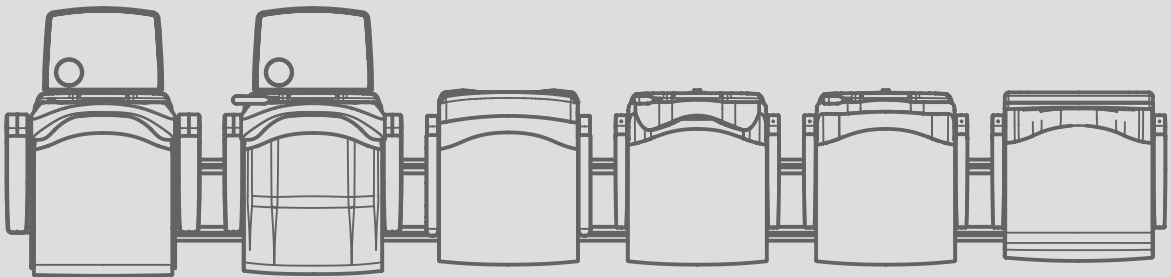
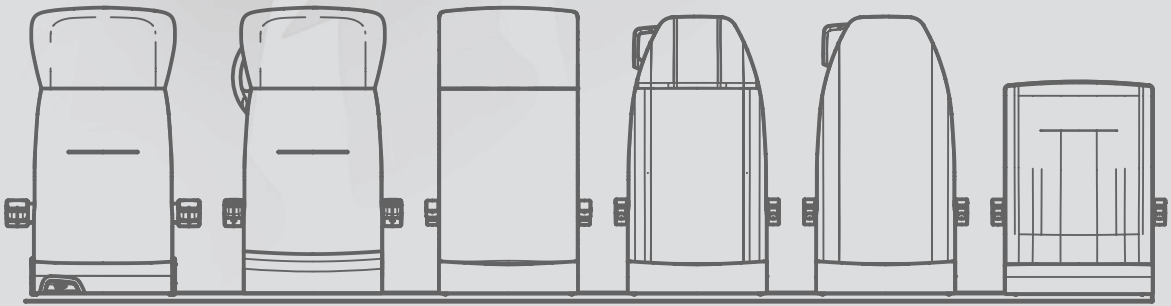





# R3000

## Thinking in modular terms – experiencing limitless comfort

Our modular designs combine top functionality with extensive adjustability and a modern look.

For this reason, the underlying platform offers broad scope for accommodating your own specific requirements, giving you the perfect solution for intercity, regional, city and underground trains.

We always have the right seat for you!



Pocket springs



Second suspension



Ergomechanics®

FEATURES	R3000
<b>Backrest versions</b>	
One-piece standard cushion	●
Low, standard	●
Low, comfort	●
<b>Seat cushion versions</b>	●
Standard	●
Comfort	●
Standard for folding seat	●
Comfort for folding seat	●
<b>Armrest versions</b>	
Fixed, 40 mm, right, left	●
Foldable, 40 mm, right, left, middle	●
<b>Backrest versions</b>	
Standard cushion	●
Comfort cushion	●
One-piece comfort cushion	
<b>Seat cushion versions</b>	
Standard	●
Comfort	●
Standard for folding seat	●
Comfort for folding seat	●
<b>Head cushion versions</b>	
Standard	●
Rectangular	●
Comfort	●
V-shaped	●
<b>Armrest versions</b>	
Fixed, 40 mm, right, left	●
Foldable, 40 mm, right, left, middle	●

OTHER ACCESSOIRES	R3000
Folding seatback tray table	○
Comfort folding seatback tray table with HPL and drink holder	○
Grap handle, basic and U.K. versions	○
Magazine net	○
Ticket holder	○
Customer logo	○
Coat hook	○
Back-to-back installation	○
Reclining	○
Seat adjustment	○
Seat attachment	○
Seat foot with wall adapter	○
Attachment to seat box	○
Cantilever	○



# IC3000

## The Comfort Seat

- This seat is designed to meet the strictest safety requirements, especially with regard to fire and crash protection. The structural components, backrest cover, and attachments optimally protect travelers in compliance with current standards in the U.K.
- The seat makes the most of available space. A range of armrests with different widths and surfaces provides flexibility for different seating configurations.



Pocket springs



Second suspension



Ergomechanics®



USB

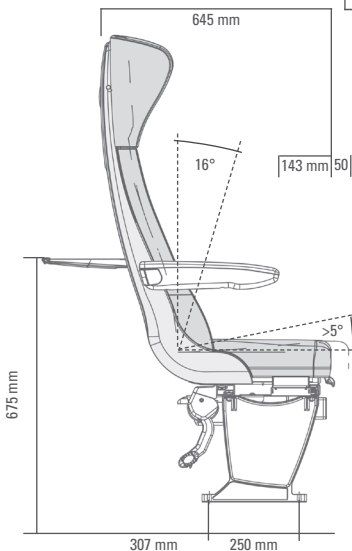
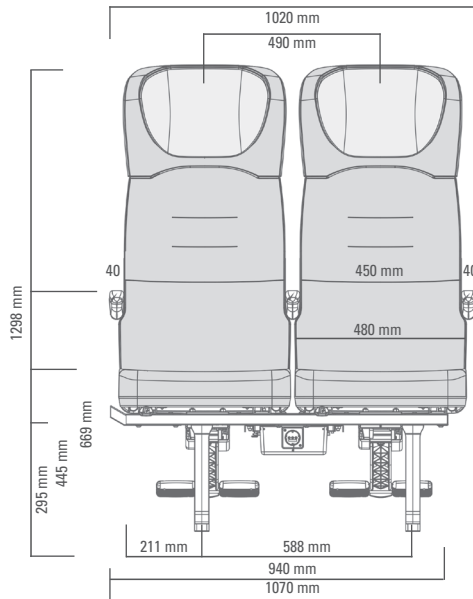

All dimensions in mm.  
Subject to technical changes.

FEATURES	IC3000
<b>Armrests</b> (choice of fixed or folding)	
Wall side (40, 50, 60, 70 mm)	●
Aisle side (40, 50, 60, 70 mm)	●
Middle (40, 50, 60, 70 mm)	●
<b>Head cushion</b>	
Standard	●
Medium	○
Various fabric patterns and grades available	○
Leather	○
<b>Pillow</b>	
Standard	●
Comfort	○
Protective cover	○
<b>OTHER ACCESSORIES</b>	
<b>Power socket</b>	○
<b>Folding table on back, comfort</b> (laptop-friendly)	○
<b>Folding table on back, standard</b>	○
<b>Cup holder</b>	○
<b>Ticket holder</b>	○
<b>Safety card holder</b>	○
<b>Waste basket</b>	○
<b>Seat numbering</b>	○
<b>Table between seats</b>	○
<b>Footrest</b>	○
<b>Seat attachment</b>	
Seat foot with wall adapter	○
Attachment to seat box	○
Cantilever	○



# C3000

## The Allrounder for short distances

- With its first-class workmanship and robust materials, the C3000 is ideal for shorter routes.
- The C3000 can be optionally equipped with protection against vandalism, also in combination with high-comfort cushions.
- The U.K. version of the C3000 complies with the strictest fire protection and crash requirements, in addition to other safety standards.
- A range of modular armrests ensures optimal use of available space in every installation situation.



Pocket springs

FEATURES	C3000
<b>Armrests</b> (choice of fixed or folding)	
Wall side (40 mm), resting or abutting	<input type="radio"/>
Aisle side (40 mm), resting or abutting	<input type="radio"/>
Middle (40 mm)	<input type="radio"/>
Middle (69 mm)	<input type="radio"/>
<b>Seat attachment systems</b>	
Seat foot with wall adapter	<input checked="" type="radio"/>
Cantilever	<input type="radio"/>
Attachment to seat box	<input type="radio"/>
<b>Cushion</b>	
Standard	<input checked="" type="radio"/>
Comfort	<input type="radio"/>
Vandalism protection	<input type="radio"/>
<b>Cover</b> (quick-changing)	<input checked="" type="radio"/>
Various fabric patterns and grades available	<input type="radio"/>
Leather	<input type="radio"/>
Protective cover	<input type="radio"/>
<b>OTHER ACCESSORIES</b>	
Standard folding table on back	<input type="radio"/>
Folding table with laptop holder	<input type="radio"/>
Grab handle	<input type="radio"/>

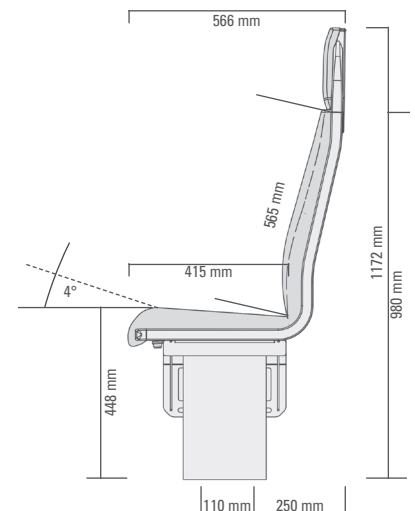
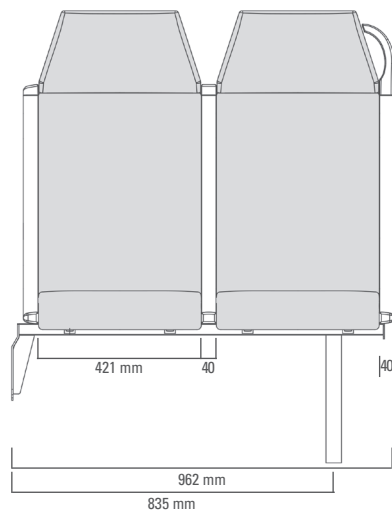

The product shown may differ from the standard configuration.





# I3000

## The new seat for city traffic

The Inncity3000 for city traffic combines attractive design with a modular lightweight concept: With a width of 450 mm its total weight stays under 5 kg. The seat is manufactured with resource-saving and easy-to-recycle plastic material. It offers numerous customizable design options such as color, thickness of the upholstery or the integration of logo elements. The ideally shaped grab handle ensures more passenger safety. A USB-port, lightning elements or a holding-function-button can be integrated in the seat.

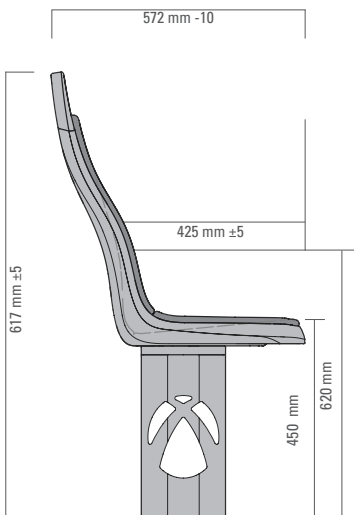
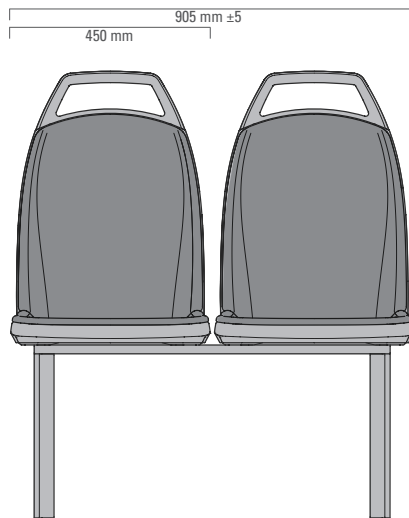

USB



Sustainability

FEATURES	INNERCITY3000
Plastic seat shell	●
Grab Handle	●
Top Cover	○
Hip Support	○
Arm rest	○
Rod holder	○
Visible plastic parts	○
Cushion high foam	●
Cushion low foam	○
Cushion without foam	○
Leather cushion	○
Branding	○
USB Port	○
Integrated LED	○
Integrated Lights	●
Signal functions	○
Displays	○



# SPECIAL SEATS

You can select your very own GRAMMER seat from our wide range of seating systems.

Our strength is our ability to offer an individual solution for each segment. And this is something from which your own customers will also benefit.

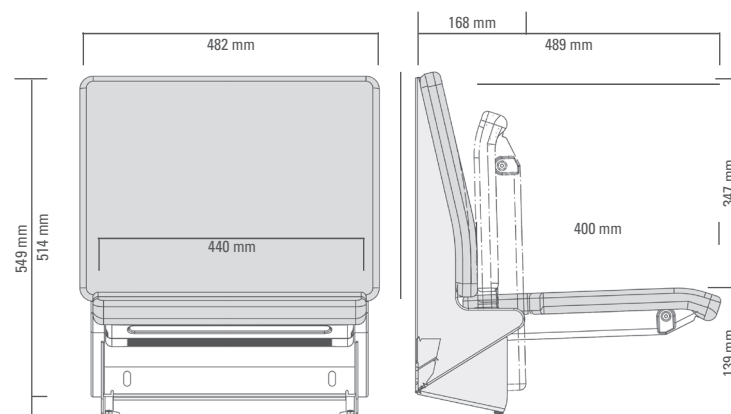
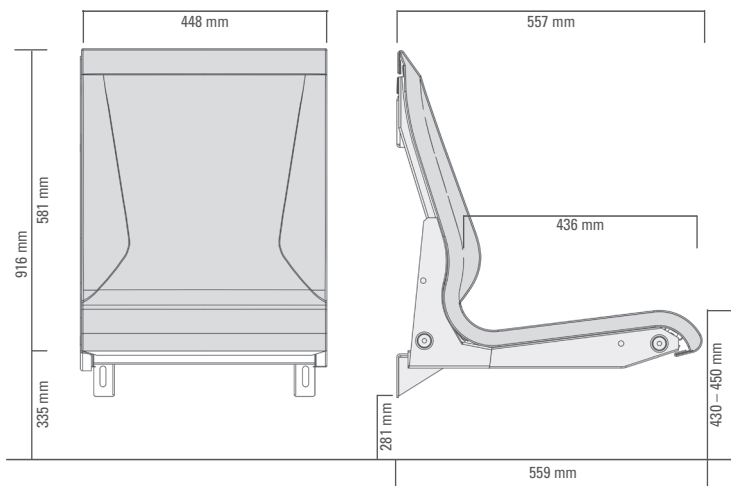



## Combining things right down to the smallest detail – creating an exclusive look

The perfect combination right down to the very last detail. You can select customized options when you configure your individual passenger seat.

Additional features provide even greater exclusiveness. Electronic components such as USB connections, power sockets or reading lamps as well as seat numbers and ticket holders offer additional scope for a unique look.

With these details you can give your seats a new dimension of perceived quality and presence that can be seen and felt.

Whether it is a particular color or exclusive materials, we fulfill your wishes.

